

## Robinet à Flotteur

**Réf.**  
**108 002**

**FONTE**

» BRIDES RF  
» ISO PN16

» TMS : 70°C  
» PMS : 16B (1)

CORPS / BODY	FONTE GS400
CHAPEAU / BONNET	FONTE GS400
PISTON / PISTON	INOX 316
SIÈGE / SEAT	INOX 316
FLOTTEUR / FLOAT	INOX 316
JOINTS / GASKETS	BUNA

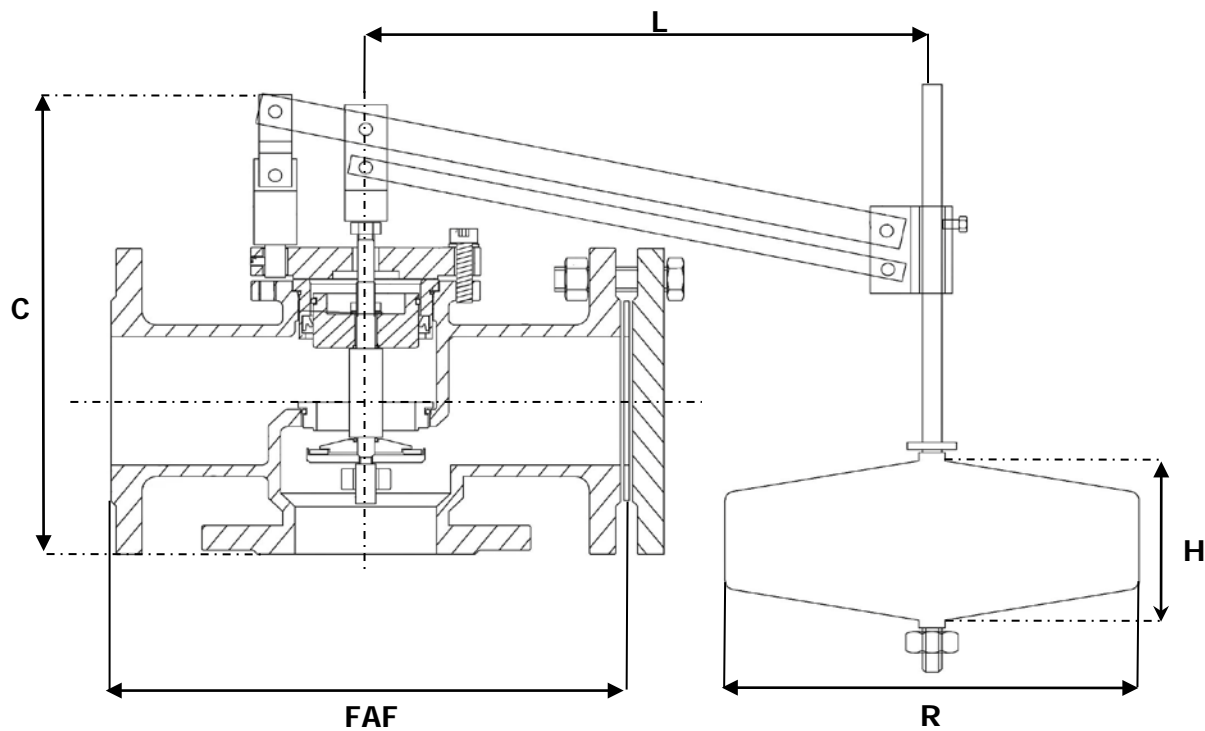

DN	8	10	15	20	25	32	40	50	65	80	100	125	150	200	250	300	350	400	450	500	600	
INCHES	1/4"	3/8"	1/2"	3/4"	1"	1 1/4"	1 1/2"	2"	2 1/2"	3"	4"	5"	6"	8"	10"	12"	14"	16"	18"	20"	24"	
FAF							230	230	290	310	350	400	480	600	600							
L							600	600	600	800	800	800	1000	1000	1000							
H							200	200	200	180	180	180	250	250	300							
R							300	300	300	400	400	400	400	400	500							
C							256	256	286	410	475	525	642	783	800							
MASSE							21	21	25,6	32,6	41	49	78,5	118,5	138							

Unités : mm, Kg.