

DINO-LURIA®

Vanne à Passage Direct

Réf :
153 100

FORTE

- » CORPS MÉPLAT
- » DIN F4
- » TIGE INTÉRIEURE
- » DIN 3202 F4 SÉRIE COURTE

- » BRIDES
- » ISO PN10 (1)

» TMS : 120°C

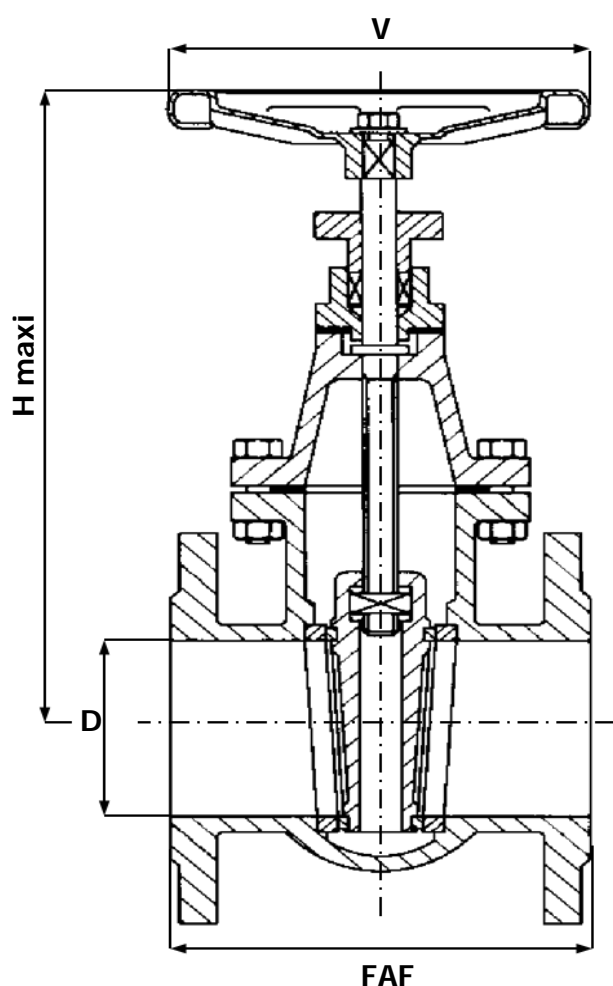

CORPS / BODY	FONTE GG 25
CHAPEAU / BONNET	FONTE GG 25
OPERCULE / WEDGE	FONTE GG 25 + LAITON ou INOX F6
SIÈGES / SEATS	LAITON ou INOX F6
TIGE / STEM	INOX F6
JOINT DE CORPS / GASKET	GRAPHITE
PRESSE ÉTOUPE / PACKING GLAND	FIBRE GRAPHITE

• AVEC SIÈGES INOX REF. : 153 105

DN	8	10	15	20	25	32	40	50	65	80	100	125	150	200	250	300	350	400	500	600	
INCHES	1/4"	3/8"	1/2"	3/4"	1"	1 1/4"	1 1/2"	2"	2 1/2"	3"	4"	5"	6"	8"	10"	12"	14"	16"	20"	24"	
(1) PN																					
FAF																					
H maxi																					
D																					
V																					
MASSE																					
						10 Bars					6 Bars					4 Bars					2,5 Bars
	140	150	170	180	190	200	210	230	250	270	290	310	350	390							
	239	253	285	307	363	443	450	515	605	692	825	866	1060	1240							
	40	50	65	80	100	125	150	200	250	300	350	400	500	600							
	120	140	160	160	180	200	200	250	280	320	320	400	500	500							
	11	14	19	22	28	53	61	66	91	169	266	307	473	563							

Unités : mm, Kg.